

# Cages and Seals

# Customer Benefits



## SPLIT BEARINGS FOR MARINE PROPULSION



SNL & SD INTERCHANGEABLE BEARINGS  
SHIP REPAIR AND RETROFITTING MADE EASY

[www.jhbsplitbearings.com](http://www.jhbsplitbearings.com)



### ROLLERTRAIN® Split Bearing Cages

#### Radial Cage – Free and Fixed Bearings

Using engineering-grade 3D-printed Nylon-11 we have developed a design that allows much closer spacing of the cylindrical rollers compared to traditional designs, creating enough additional space around the roller track to incorporate more rollers, increasing the radial capacity of the bearing.

#### Axial Cage – Fixed Bearings

JHB Split Bearings use our patented and patent pending ROLLERTRAIN® technology to handle bi-directional axial loads via the use of two completely independent axial bearings – compared to existing manufacturers lipped race designs. Inserting an axial bearing either side of the JHB free bearing converts the bearing into a fixed bearing. JHB Split Bearing inner housings (cartridges) are ALL machined to accept these axial bearings as standard. By utilising this design we are able to increase the axial capacity of the bearing by around 1000% as axial loads are now handled by true rolling element bearings, whilst also allowing an axial L10 life to be calculated.

By removing the axial locating lips from the bearing outer race, the radial roller length can be increased, and along with the previously mentioned increase in number of rollers, gives an approximate 70% increase in bearing capacity or an increase of 5X radial L10 life.

Both cages make use of ROLLERTRAIN®'s unique roller interlock jointing resulting in run-safe cage & roller assemblies as there are no cage clips, spring plates or cage joint screws added to the roller track.



#### Ease of conversion:

Minimal disruption; install directly in existing SNL housings, which can be left in place. No need to remove ancillary equipment or alter the shaft alignment

#### Ease of fitting:

Smaller, lighter components. Factory set clearances. No specialist tools required

#### Triple Labyrinth sealed inner housings (cartridges) only:

Triple Labyrinth sealed inner housings with variations to suit any sealing requirement

#### Interchangeable parts:

All bearing components (match-marked races, match-marked clamp rings, and cage & roller assemblies) are interchangeable between bearings within the same size group. This enables bearings to be stocked as component parts rather than built-up items, maximising product availability whilst minimising stock holding

#### Increased clamp force and dowel ability:

Increased clamp force of the bearing on the shaft as well as the ability to dowel the inner race to the shaft underneath the clamp ring

#### Independent loads:

Radial and (bi-directional) axial loads are handled independently by THREE independent sets of rolling elements – competitors use one (or two) sets of rolling elements to handle the three load directions. The JHB Split Bearings suffer no loss of radial capacity with variation in axial load

#### Huge stock profile:

We hold approximately 0.5 million GBP of 1.5 inch to 6 inch units in stock as well as 0.5 million GBP of the 6.5 inch to 12 inch units

#### Bespoke design:

Bespoke bearing design and manufacturing service available with very short lead times. As bearing components are interchangeable, bespoke bearings can be 'built up' from stock items

#### Easy modifications:

Modifications to the core product are able to be carried out with ease and with extremely short lead times as the JHB Split Bearing requires no tooling, making small quantities extremely cost-effective

#### Seal modifications:

Modifications such as non-standard bore, waterproof seals and flinger additions are all easily and quickly achievable

#### Highest radial capacity of ANY split bearing:

The JHB split bearing's radial capacity equates to either a 70% increase in radial load or 5x bearing radial L-10 life

#### Highest axial capacity of ANY split bearing:

1000% increased axial capacity and the very first split bearing to calculate an axial L-10 bearing life

#### Easy fit cages and seals:

The SEALTRAIN® and ROLLERTRAIN® seals and cages have been designed for unprecedented ease of use. The seals are a simple click-fit and the cages employ unique jointing with no joint clips/spring plates

#### Fast delivery:

All stock is available with next day delivery - subject to customer location

#### Technical support:

Full technical support from our dedicated Bowman Advanced Engineering team, including engineering, 3D design and product support as well as site visits, service engineers and application engineers all over the globe

[www.jhbsplitbearings.com](http://www.jhbsplitbearings.com)

[www.johnhandleybearings.com](http://www.johnhandleybearings.com) [sales@johnhandleybearings.com](mailto:sales@johnhandleybearings.com)

+44 (0) 1902 898 560

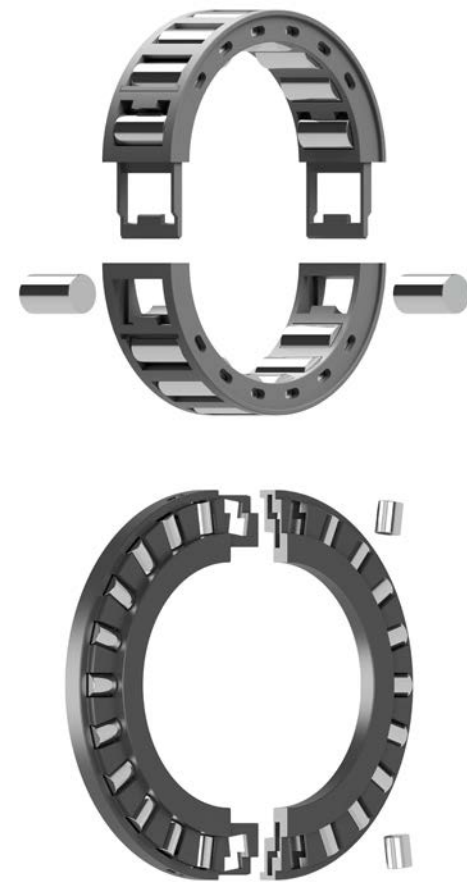

### SEALTRAIN® Split Triple Labyrinth Seals

Our new range of split triple labyrinth seals are made from Nylon PA11. They are less than 40% of the weight of aluminium seals and can drop-in replace seals from existing manufacturers. Incorporating viton o-rings as standard. The SEALTRAIN® triple labyrinth seals are non-sparking and can be fitted/released in seconds using the handy release tool which comes as standard with every seal.

# Ship Repairs and Retrofitting Made Easy With SNL & SD



JHB Bearings are split, so you don't have to take the time to split the drive line. With all parts in two halves, the bearing, seals and housing can be radially assembled around the shaft. Dismantling and removing drive line components such as couplings, is no longer necessary, saving time and money

JHB now offers their high capacity split roller bearings to replace spherical roller bearings in difficult to reach propulsion shaft positions on workboats, support vessels, tugs and many other marine applications, by utilizing existing SNL or SD bearing housings and incorporating the benefits of the JHB split bearing to overcome complicated solid bearing replacement issues.

Typically, spherical roller bearings fitted in SNL or SD types of housings would require the shaft to be removed to replace the bearings. Dismantling couplings and moving other machinery would involve heavy lifting in confined spaces. By using split bearings in the existing housings, there are numerous benefits available to both installers and ship operators.

- ▶ Cuts downtime dramatically – vessel remains in the water
- ▶ Shafts, couplings and ancillary equipment can be left in-situ
- ▶ Install directly into existing SNL & SD housings, which can be left in place (fixed with their dowels, chocks or set in resin compound)
- ▶ Easy to replace and periodically inspect bearings without removing the shaft
- ▶ Split bearings come with factory pre-set internal clearance – no complicated setting when installing bearings on shaft
- ▶ Smaller components, in halves, means no heavy lifting tackle is required
- ▶ Maintains existing shaft alignment – does not require re-alignment, often provided by additional specialized contractors
- ▶ Composite triple labyrinth seals are supplied as standard
- ▶ +/- 2° static misalignment capability within the housing arrangement
- ▶ Inner housing always aligns seals concentric with the shaft
- ▶ JHB's high capacity thrust / locating bearing for axial loads
- ▶ JHB Split Bearing can accommodate high radial loads and high axial loads simultaneously
- ▶ Ex-stock or short lead times by using off the shelf components

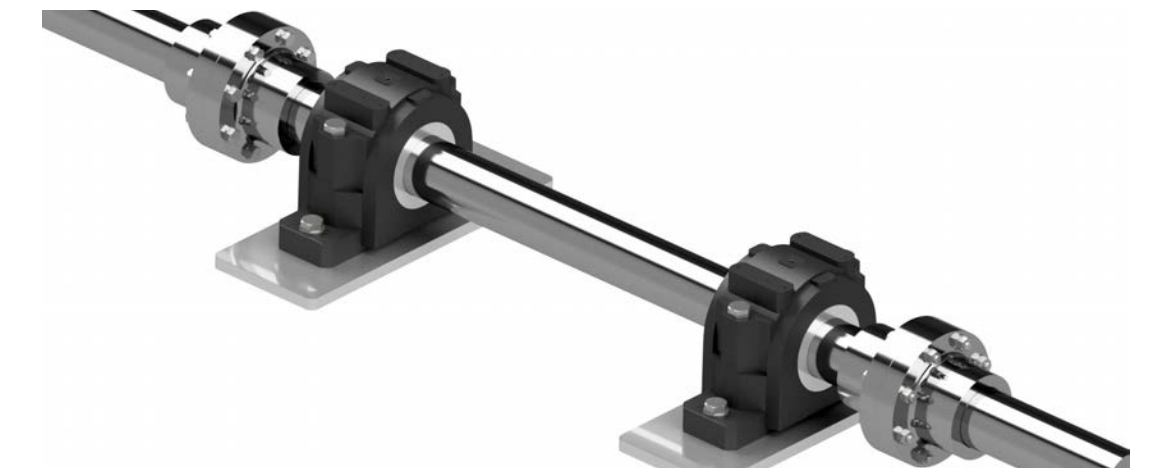

## The Bowman Group

The Bowman Group is a group of divisions dedicated to innovation, reliability and quality customer service within the engineering sector. The Bowman Group includes Bowman International, one of the UK's leading plain bearings manufacturers and distributors; Bowman Additive Production, the 3D printing division of the group with the aim of revolutionizing manufacturing processes through additive technologies; Bowman Advanced Engineering, the technical wing of the group focused on innovation and new products and John Handley Bearings, one of the most trusted names in the bearings industry for over 60 years.

